



Fall 2011 Prospectus

An Open Industry Cloud Network
Performance, Virtualization & Power Consumption Test
Invitation

Evaluating 10 & 40 GbE

For

Data Center Ethernet Fabrics

By

Lippis Enterprises

May 2011

The Prospectus

What: Our industry is ramping up to build private and public cloud infrastructure, but IT architects do not have comparative 10 and 40 GbE Data Center Switch/Fabric performance information to assist them in purchase decisions and product differentiation. New data center Ethernet fabric design requires low latency, high performance under north-south plus east-west flows, low power consumption and minimum number of network tiers. During past industry cycles open industry tests contributed to growing the network market by shortening sales cycles due to the elimination of IT departments conducting internal performance test. In addition, performance question obstacles were eliminated during the sales cycle thanks to reliable industry data being available, speeding up market adoption. This was true in the LAN plus bridge/router industry battles as well as every major Ethernet switch evolution. There is no broad industry comparative 10 and 40 GbE fixed and modular switch performance test available.

Lippis Enterprises has developed a series of open industry performance tests and teamed with Ixia for their execution. The goal of the evaluation is to provide the industry with comparative performance test data across all 10 and 40 GbE switch providers. Both modular switching (Core plus End-of-Row) products and fixed (Blade & Top-of-Rack) configuration switches are welcome. The final test report will profile each supplier and segment products based upon modular or fixed configuration.

Who: The test is open to all suppliers of 10 & 40 Gigabit Ethernet switching equipment, both modular and fixed configurations. In fact we encourage all suppliers to enter the test.

Where: The test will take place in the modern Ixia test lab named iSimCity located in Santa Clara, CA. Ixia will supply all test equipment needed to conduct the performance tests.

When: This test is scheduled for the week of **Oct 3 - 7, 2011**. Each supplier will be allocated time to run the test during this test week. Vendor sign up is closed at end of business day PT Monday **August 1, 2011**.

How: Each supplier will bring their own engineers to accompany their equipment to be tested. An Ixia test engineer will be available to assist each supplier through test methodologies. The supplier's engineer will sign-off on the test data results at the completion of the test. The Lippis Report Test Methodologies include the following Ixia test suites and scripts:

IxNetwork Suite

1. RFC 2544 Latency
 - a. L2 and L3
 - b. Expecting 100% throughput with no loss
 - c. Measure with latency on to get min/max/avg
 - d. Measure with jitter on to get jitter measurement
2. RFC 2889 Congestion
 - a. L2 and L3
 - b. Four port setup as defined by the RFC
3. Cloud test
 - a. Custom configuration same as first round
 - b. Expecting no loss on traffic run
 - c. Measure latency
4. Power measurement
 - a. Run at rates of 0, 30 and 100% line rate
 - b. Take manual power measurements
5. RFC 3918 Multicast Throughput
 - a. Measure latency

Virtualization Scale Test/Calculation

Throughput Performance: Throughput, packet loss and delay for layer-2 (L2) unicast, layer-3 (L3) unicast and layer-3 multicast traffic is measured for packet sizes of 64,128, 256, 512, 1024, 1280, 1518, 2176, 9216 bytes. In addition, a special cloud computing simulation throughput test consisting of a mix of north-south plus east-west traffic is conducted. Ixia's IxNetwork RFC 2544 Throughput/Latency quick test is used to perform all but the multicast tests. Ixia's IxAutomate RFC 3918 Throughput No Drop Rate test is used for the multicast test.

Latency: Latency is measured for all the above packet sizes plus the special mix of north-south and east-west traffic blend. Two latency tests are conducted: 1) latency is measured as packets flow between two ports on

different modules for modular switches, and 2) between far away ports (port pairing) for ToR switches to demonstrate latency consistency across the forwarding engine chip. Latency test port configuration is via port pairing across the entire device versus side-by-side. This means that a switch with N ports, port 1 was paired with port $(N/2)+1$, port 2 with port $(N/2)+2$, etc. Ixia's IxNetwork RFC 2544 Throughput /Latency quick test is used for validation.

Jitter: Jitter statistics are measured during the above throughput and latency test using Ixia's IxNetwork RFC 2544 Throughput/Latency quick test.

Congestion Control Test: Ixia's IxNetwork RFC 2889 Congestion test is used to test both L2 and L3 packets.

The objective of the Congestion Control Test is to determine how a Device Under Test (DUT) handles congestion. Does the device implement congestion control and does congestion on one port affect an uncongested port? This procedure determines if Head-of-Line (HOL) blocking and/or if back pressure are present. If there is frame loss at the uncongested port, HOL blocking is present. Therefore, the DUT cannot forward the amount of traffic to the congested port, and as a result, it is also losing frames destined to the uncongested port. If there is no frame loss on the congested port and the port receives more packets than the maximum offered load of 100%, then back pressure is present.



Video feature: [Click Here](#) to view a discussion on the Lippis Report Test Methodology

RFC 2544 Throughput/Latency Test

Test Objective: This test determines the processing overhead of the DUT required to forward frames and the maximum rate of receiving and forwarding frames without frame loss.

Test Methodology: The test starts by sending frames at a specified rate, usually the maximum theoretical rate of the port while frame loss is monitored. Frames are sent from and received at all ports on the DUT, and the transmission and reception rates are recorded. A binary, step or combo search algorithm is used to identify the maximum rate at which no frame loss is experienced.

To determine latency, frames are transmitted for a fixed duration. Frames are tagged once in each second and during half of the transmission duration, then tagged frames are transmitted. The receiving and transmitting timestamp on the tagged frames are compared. The difference between the two timestamps is the latency. The test uses a one-to-one traffic mapping. For store and forward DUT switches latency is defined in RFC 1242 as the time interval starting when the last bit of the input frame reaches the input port and ending when the first bit of the output frame is seen on the output port. Thus latency is not dependent on link speed only, but processing time too. Cut-Through (CT) and Store and Forward (S&F) test will be conducted at the vendor's option, but only like approaches will be compared. A vendor may test for both CT and S&F.

Results: This test captures the following data: total number of frames transmitted from all ports, total number of frames received on all ports, percentage of lost frames for each frame size plus latency, jitter, sequence errors and data integrity error. The following graphic depicts the RFC 2554 throughput performance and latency test to be conducted at the iSimCity lab for each product.

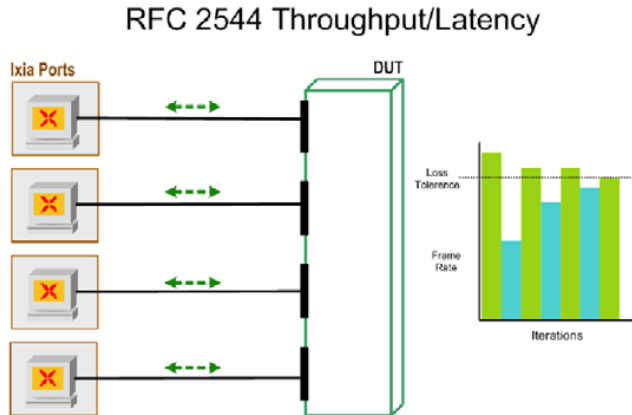

RFC 2889 Congestion Control Test

Test Objective: The objective of the Congestion Control Test is to determine how a DUT handles congestion. Does the device implement congestion control and does congestion on one port affect an uncongested port? This procedure determines if HOL blocking and/or if back pressure are present. If there is frame loss at the uncongested port, HOL blocking is present. If the DUT cannot forward the amount of traffic to the congested port, and as a result, it is also losing frames destined to the uncongested port. If there is no frame loss on the congested port and the port receives more packets than the maximum offered load of 100%, then back pressure is present.

Test Methodology: If the ports are set to half duplex, collisions should be detected on the transmitting interfaces. If the ports are set to full duplex and flow control is enabled, flow control frames should be detected. This test consists of a multiple of four ports with the same MOL (Maximum Offered Load). The custom port group mapping is formed of two ports, A and B, transmitting to a third port C (the congested interface), while port A also transmits to port D (uncongested interface).

Test Results: This test captures the following data: intended load, offered load, number of transmitted frames, number of received frames, frame loss, number of collisions and number of flow control frames obtained for each frame size of each trial are captured and calculated. The graphic depicts the RFC 2889 Congestion Control test to be conducted at the iSimCity lab for each product.

RFC 3918 IP Multicast Throughput No Drop Rate Test

Test Objective: This test determines the maximum throughput the DUT can support while receiving and transmitting multicast traffic. The input includes protocol parameters (IGMP, PIM), receiver parameters (group addressing), source parameters (emulated PIM routers), frame sizes, initial line and search type.

Test

Methodology:

This test calculates the maximum DUT throughput for IP Multicast traffic

using either a binary or a linear search, and to collect Latency and Data Integrity statistics. The test is patterned after the ATSS Throughput test; however this test uses multicast traffic. A one-to-many traffic mapping is used, with a minimum of two ports required. If choosing OSPF or ISIS as IGP protocol routing, the transmit port first establishes an IGP routing protocol session and PIM session with the DUT. IGMP joins are then established for each group, on each receive port. Once protocol sessions are established, traffic begins to transmit into the DUT and a binary or linear search for maximum throughput begins.

If choosing “none” as IGP protocol routing, the transmit port does not emulate routers and does not export routes to virtual sources. The source addresses are the IP addresses configured on the Tx ports in data frame. Once the routes are configured, traffic begins to transmit into the DUT and a binary or linear search for maximum throughput begins.

Test Results: This test captures the following data: maximum throughput per port, frame loss per multicast group, minimum/maximum/average latency per multicast group and data errors per port. The following graphic depicts the RFC 3918 IP Multicast Throughput No Drop Rate test to be conducted at the iSimCity lab for each product.

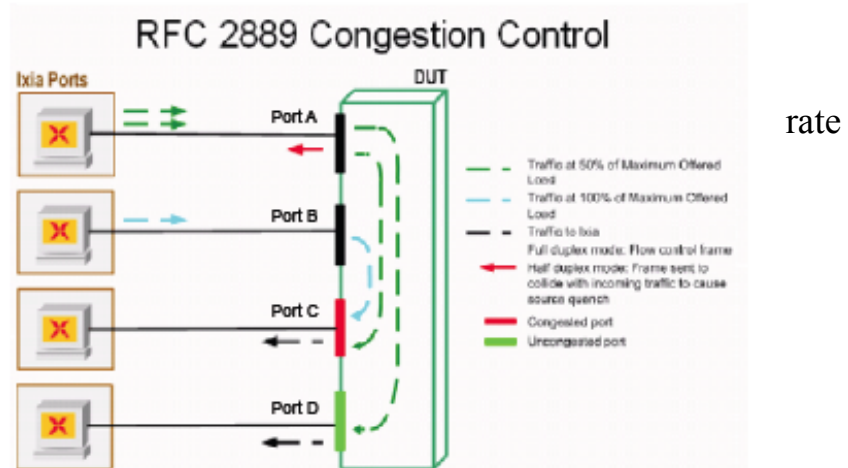

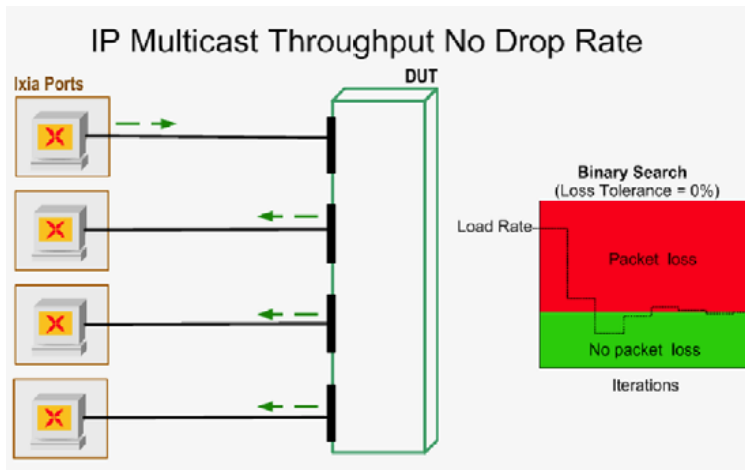

Power Consumption Test

Port Power Consumption: Ixia's IxGreen within the IxAutomate test suite is used to test power consumption at the port level under various loads or line rates.

Test Objective: This test determines the Energy Consumption Ratio (ECR), the ATIS (Alliance for Telecommunications Industry Solutions) Telecommunications Energy Efficiency Ratio (TEER) during a L2/L3 forwarding performance. TEER is a measure of network-element efficiency quantifying a network component's ratio of "work performed" to energy consumed.

Test Methodology: This test performs a calibration test to determine the no loss throughput of the DUT. Once the maximum throughput is determined, the test runs in automatic or manual mode to determine the L2/L3 forwarding performance while concurrently making power, current and voltage readings from the power device. Upon completion of the test, the data plane performance and Green (ECR and TEER) measurements are calculated. Engineers follow the methodology prescribed by two ATIS standards documents:

ATIS-0600015.03.2009: Energy Efficiency for Telecommunication Equipment: Methodology for Measuring and Reporting for Router and Ethernet Switch Products, and

ATIS-0600015.2009: Energy Efficiency for Telecommunication

Equipment: Methodology for Measuring and Reporting -General Requirements

The power consumption of each product is measured at various load points: idle 0%, 30% and 100%. The final power consumption is reported as a weighted average calculated using the formula:

$WATIS = 0.1*(\text{Power draw at 0\% load}) + 0.8*(\text{Power draw at 30\% load}) + 0.1*(\text{Power draw at 100\% load})$.

All measurements are taken over a period of 60 seconds at each load level, and repeated three times to ensure result repeatability. The final WATIS results are reported as a weighted average divided by the total number of ports per switch to derive at a WATTS per port measured per ATIS methodology and labeled here as WATTSATIS.

Test Results: The L2/L3 performance results include a measurement of WATIS and the DUT TEER value. Note that a larger TEER value is better as it represents more work done at less energy consumption. We use WATTSATIS to identify ATIS power consumption measurement on a per port basis.

With the WATTSATIS we calculate a three-year energy cost based upon the following formula.

$\text{Cost/WattsATIS/3-Year} = (\text{WATTSATIS} / 1000) * (3 * 365 * 24) * (0.1046) * (1.33)$, where WATTSATIS = ATIS weighted average power in Watts

$3 * 365 * 24 = 3 \text{ years @ } 365 \text{ days/yr @ } 24 \text{ hrs/day}$

0.1046 = U.S. average retail cost (in US\$) of commercial grade power as of June 2010 as per Dept. of Energy Electric Power Monthly

(http://www.eia.doe.gov/cneaf/electricity/epm/table5_6_a.html)

1.33 = Factor to account for power costs plus cooling costs @ 33% of power costs.

The following graphic depicts the per port power consumption test to be conducted at the iSimCity lab for each product.

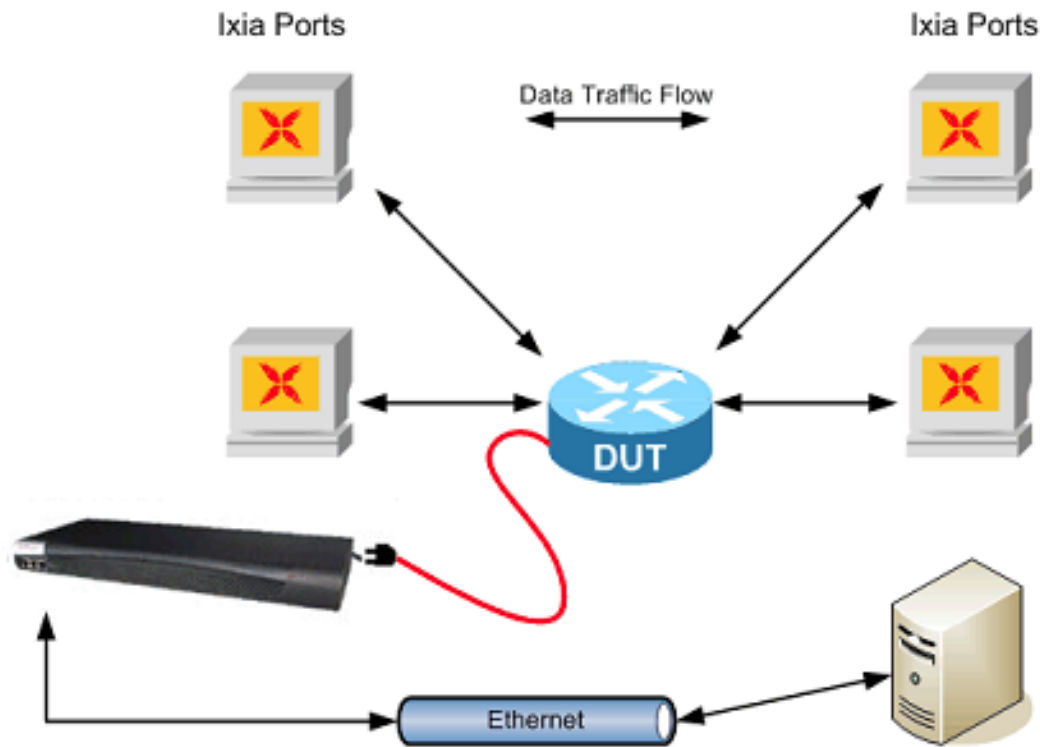

Cloud Simulation Test

Test Objective: This test determines the traffic delivery performance of the DUT in forwarding a variety of north-south and east-west traffic in cloud computing applications. The input parameters include traffic types, traffic rate, frame sizes, offered traffic behavior and traffic mesh.

Test Methodology: This test measures the throughput, latency, jitter and loss on a per application traffic type basis across M sets of 8-port topologies. M is an integer and is proportional to the number of ports the DUT is populated with. This test includes a mix of north-south traffic and east-west traffic, and each traffic type is configured for the following parameters: frame rate, frame size distribution, offered traffic load and traffic mesh. The following traffic types are used: web (HTTP), database-server, server-database, iSCSI storage-server, iSCSI server-storage, client-server plus server-client. The north-south client-server traffic simulates Internet browsing, the database traffic simulates server-server lookup and data

retrieval, while the storage traffic simulates IP-based storage requests and retrieval. When all traffic is transmitted, the throughput, latency, jitter and loss performance are measured on a per traffic type basis. Participating vendors will receive the scrip to run the cloud simulation in their lab on Ixia test equipment, if requested.

Test Results: This test captures the following data: maximum throughput per traffic type, frame loss per traffic type, minimum/maximum/average latency per traffic type, minimum/maximum/average jitter per traffic type, data integrity errors per port and CRC errors per port. For the final test report we show average latency on a per traffic basis at zero frame loss. The following graphic depicts the Cloud Simulation test to be conducted at the iSimCity lab for each product.

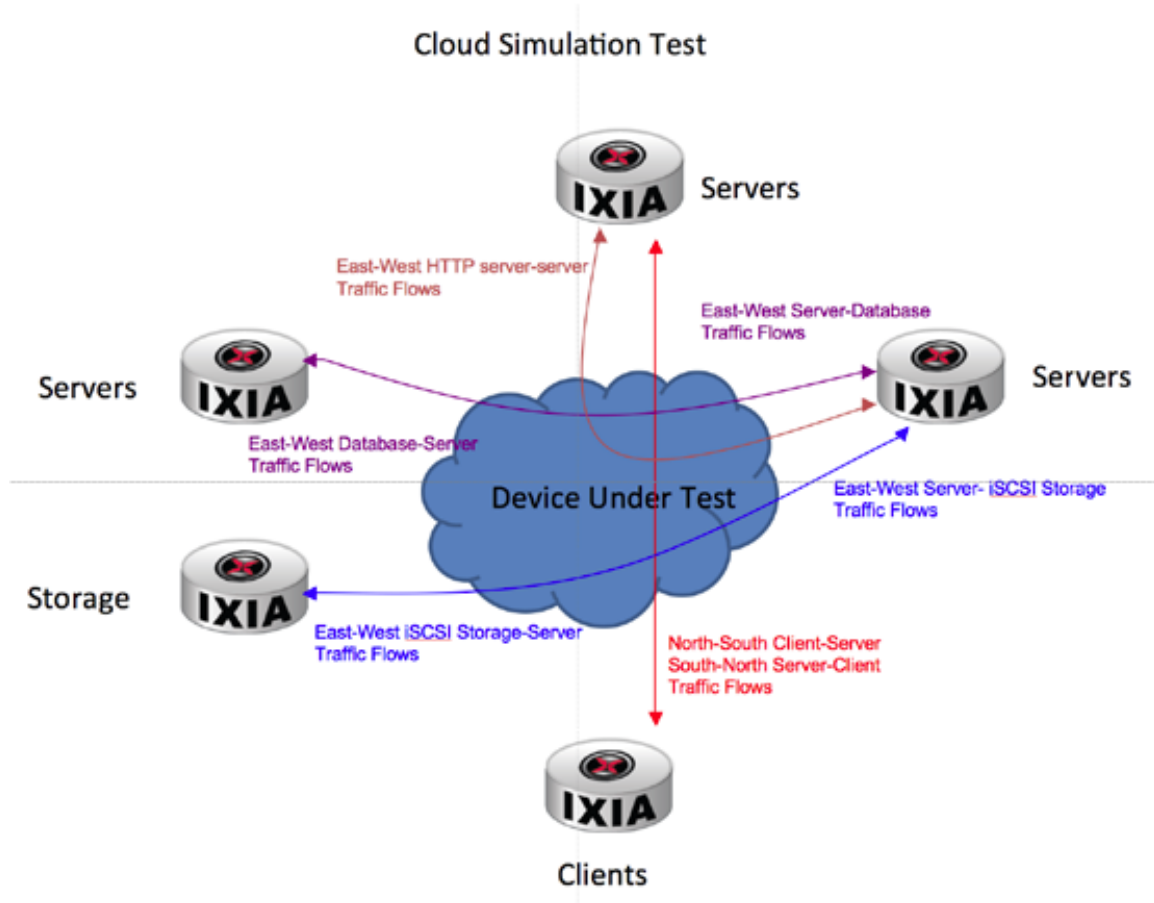

Virtualization Scale Calculation

We will either measure via RFC 2889 or observe via technical specifications

the MAC address, /32 IP host route table size and ARP entry size to calculate the largest number of VMs supported. Each VM will footprint in a switch, especially a modular/core switch (1) MAC entry, (1) /32 IP host route, and (1) ARP entry. Further, each physical server may use (2) MAC/IP/ARP entries, one for management, one for IP storage and/or other uses, etc. Therefore, the lowest common denominator of the three (MAC/IP/ARP) entries will determine the total number of VM and physical machines that can reside underneath in an L2 domain.

If the switch has a 128K MAC table, 32K IP host routes, and 8K ARP table = 8K VM+Phy servers. From here we can utilize a VM:Phy consolidation ratio to determine the approximate maximum # of Phy servers. 30:1 is a typical conservative ratio today but more dense (12) core processors entering the market may increase this ratio to 60:1, etc. With 8K total IP endpoints @ 30:1 calculates an approximate 250 Phy servers, and 7750 VMs.

250 Phy servers fits into about (12) 48-pt ToR switches, assuming each server connects to (2) ToR for redundancy. If each ToR had 8x10G links to each core, that's 96 10G ports used on the core switch.

So we can begin to see how the table size scalability of the switch determines how many of its 10GbE ports, for example, can be used and therefore how large a cluster can be built a cluster. This calculation assumes the core is the L2/L3 boundary, providing an L2 infrastructure for the VMs.

40GbE Testing

For the test above, 40GbE ports are available for test setup for those DUT that supports 40GbE uplinks or modules. Before test week we will announce the maximum number of 40GbE ports supported for this test. ToR switches with 4-40GbE uplinks are supported in this test.

As most of the throughput and latency tests outlined above configure DUT via point-to-point, a pairing up of 40GbE ports in the DUT will be supported. In addition, pairing four or more 10GbE ports to one 40GbE port is also supported for congestion, throughput and latency testing. Therefore, this test will accommodate 4x10GbE to 1x40GbE setups allowing port counts to multiply up.

The above described cloud test will offer unique attributes to demonstrate the value of 40GbE uplinks as test equipment transmit various protocols through a 40GbE uplink.

Optional Test

The following tests are optional and will not be published in the full test report published by the Lippis Report. Participating vendors will include their choice to participate in these optional test and which ones below. Further, participation in optional testing requires that the vendor acquire a custom report license, which can be obtained by sending mail to nick@lippis.com.

LAG Hashing Test: The DUT will be configured in eight ports, then seven with the same traffic flow and same number of packets while latency and throughput are measured.

Latency With Variable Packet Size. Three types of traffic will be generated including web traffic, market data traffic, file system traffic (jumbos). RFC 2544 latency test will run while different traffic types flow measuring latency and throughput. We will compare and contrast latency across the different flow types.

Buffer Testing: Traffic over subscription at 2:1 and 3:1 is configured for the DUT then throughput and packet losses are measured measure.

ECMP Scale Test: Many large cloud/web companies are implementing L3/ECMP based designs. To test ECMP scale we will configure the DUT in a 16-way, and/or 32-way ECMP for ToR to Core.

Any-to-Any and/or Hadoop: Latency: This test will simulate any-to-any traffic and measure latency. We will use Sec 5.1 and 5.2 of RFC 2889. RFC 2889 are fully meshed and partial meshed throughput/loss tests that have similarities to Hadoop and MapReduce distributed computing traffic flows found in a "Big Data" or Web 2.0 cloud data center (FB, Yahoo, Google, etc.).

Network Operating System Reliability Test: While performing RFC 2544 to the DUT the network operator will be asked to shut down the following processes to observe resiliency/self healing: CLI, STP, SNMP.

We will be looking for dropped packets and reduced throughput as these processes are shut down.

FAQ

What does it cost to participate?

There is no cost to participate in the test.

Can a vendor obtain the Lippis Report test scripts before test week at iSimCity to test their equipment in their own lab?

Yes. A vendor may acquire a custom report license, which includes the Lippis Report Test scripts before test week at iSimCity. This license enables vendors to test their equipment with the exact Lippis Report test scripts that will be used during test week assuring that a vendor knows its results before its products are tested in public. Please contact Nick Lippis at nick@lippis.com for the fall 2011 license agreement.

Can a vendor test their equipment before their scheduled test at iSimCity?

Yes. A professional services fee of \$10,000 plus lab time and other equipment cost are applied to pre-test request independent upon the location of those test, that is be it remotely monitored or in the iSimCity lab. The professional services fee must be paid before pre-testing is conducted. Please contact Nick Lippis at nick@lippis.com for more information.

Can a vendor re-test their equipment at iSimCity after their scheduled test?

Yes. A professional services fee of \$10,000 plus lab time and other equipment cost are applied to re-test request independent upon the location of those test, that is be it remotely monitored or in the iSimCity lab. The professional services fee must be paid before re-testing is conducted. Please contact Nick Lippis at nick@lippis.com for more information.

To assure the final test report is not delayed while a vendor re-tests their equipment, re-testing will only be available for two weeks after the first test

is conducted. That is re-testing of equipment is not available after October 21, 2011, unless mutually agreed upon by vendor and Lippis Enterprises.

Can I drop out before test week?

Once a company executive signs this agreement, the company is committed to the test. A drop-out fee of \$25,000 will be issued if the company does not show up for its scheduled time slot or cancels its participation at any time between signing the agreement and its scheduled test slot.

Can an equipment supplier pull their test data from being included in the final report after their product has been tested?

No.

Who owns the performance data results?

Lippis Enterprises is the exclusive owner of all test data results including spreadsheets, reports, video and audio podcast, plus still photos taken during test week. Products tested will be included in the current test report and potentially subsequent test reports, presentations etc., at the discretion of Lippis Enterprises' Inc.

What will be done with the test results?

Lippis Enterprises will write an industry report that details the test methodologies, product categorization, if needed, and test results per test. [Click here](#) for a copy of the Spring 2011 report. Both Ixia and Lippis Enterprises will review and approve the final report before it's made public. This report will be published in Mid November 2011.

Can equipment suppliers provide a short two-paragraph product description to be included in the final report?

Yes. We encourage suppliers to identify their product's unique value beyond performance and will include a fact-based report of no more than two paragraphs.

How will test results be communicated to the industry?

The test results will be communicated to the industry via a live online event either by internet video session or web conferencing promoted via the lippisreport, social networking plus traditional business and trade press. The final report will be available on the lippisreport.com site. The test report will be promoted via social networking sites, the Lippis Report subscribers of 35,000 IT business leaders as well as available to traditional business and trade reporters.

Previous Lippis/Ixia test reports were covered in the Wall Street Journal, Light Reading and numerous other industry and news outlets.

Can an executive of my company be interviewed during test week for a Lippis video podcast?

Yes, there will be a sign-up schedule for video podcast interviews during test week. Lippis/Ixia will have a photographer and videographer along with staging to record short video interviews to be included in the final report and used for its promotion. The recording of video interviews are at the discretion of Lippis Enterprises and Ixia and thus make no guarantee that video podcast will be recorded during test week.

Can equipment suppliers promote the availability of the final report and test result announcement event?

Yes, Lippis Enterprises and Ixia will provide copy to promote the live test result event.

Can equipment suppliers use the test results in our own marketing?

Yes, Lippis Enterprises will license sections of the report and/or customize a report to participating equipment suppliers. The fall 2011 license agreement is available; please contact nick@lippis.com to request a copy. We encourage every participating supplier to review the license agreement to maximize its use and value of this industry event.

Those who acquire a custom report license will be granted rights to the custom report, Lippis Report test configuration, still photos, video podcast and a plaque for display at Interop et al that says something to the effect of "This Product Was Tested by The Lippis Report/Ixia Data Center Switching Benchmark Tests". Further, participating firms who acquire a custom

license may issue press releases after the full test report is completed. The Lippis Report will issue an email to all firms who have acquired a custom license as when they may issue press releases. Quotes from Nick Lippis are available upon request and approval.

Sample custom test reports can be downloaded here:

<http://enterprise.alcatel-lucent.com/?product=OmniSwitch10K&page=overview>

<http://info.bladenetwork.net/lippis>

http://www.force10networks.com/company/forms/campaigns.asp?campLSD=LippisReport_Jan2011

Note that all firms that acquired a custom test report license used them to create a press release to market their results, posted the report on their web sites and distributed it to their sales and channel partners to win business.

Can both modular and fixed 10/40GbE switches participate?

Yes. We encourage Top-of-Rack, End-of-Row and Core 10/40 Gigabit Ethernet switch products to participate.

Why isn't storage enablement/convergence included in the test?

While storage enablement is a high priority to those IT business leaders seeking the value of convergence we didn't want to complicate this test. Storage enablement will be included in a future test.

How do I assure my company's participation in this test?

All that is required is that an authorized executive sign the prospectus agreement below **BEFORE AUGUST 1, 2011** and email it to both Nick Lippis nick@lippis.com and Michael Githens mgithens@ixiacom.com. Upon receiving a signed authorization, Nick Lippis will schedule your company's test slot at iSimCity. There are a limited number of test slots available and we will assign them on a first come, first serve basis.

In signing below the vendor acknowledges and agrees to the above terms of

the “Open Industry Cloud Network Performance and Power Consumption Test Evaluating 10 & 40 Gigabit Ethernet Data Center Switching” by Lippis Enterprises taking place at Ixia’s iSimCity.

Further, in signing below the vendor acknowledges and agrees to release the use of the company’s name as a participant in the “Open Industry Cloud Network Performance and Power Consumption Test Evaluating 10 & 40 Gigabit Ethernet Data Center Switching” by Ixia & Lippis Enterprises.

Potential marketing activities include a press release outlining the test evaluation event, possible press interviews during and after test week plus video and/or audio broadcasting tweeting, social network post and podcasting of the event. Participant also understands that individual company names will not be used, but in conjunction with all participants in the event.

Participant understands that neither Lippis Enterprises nor Ixia will release the results of the test or of individual vendor testing until after the test week event is complete. If requested to be interviewed by media, participating company has the right to decline an interview—whether in writing, audio or video.

Lippis Enterprises and Ixia look forward to working with you in accordance with our general provisions and contributing to growing the data center Ethernet fabric network market through delivering trusted independent performance data to the industry.

Optional Test Selection:

Which optional test does your company request? Check and circle all optional test requesting.

- LAG Hashing Test**
- Latency With Variable Packet Size Test**
- Buffer Test**
- ECMP Scale Test**
- Any-to-Any and/or Hadoop Test**
- Network Operating System Reliability Test**

Accepting for: **Equipment Supplier**

By: _____
Authorized Signature _____ Please Print Name

Title: _____

Date: _____

PO#: _____

General Provisions

We will devote reasonable professional efforts to carrying out the work required. The results obtained, our recommendations, and written material will be our best judgment based upon the information available to us.

All test data and test report content contemplated by this Agreement are protected by United States and international copyright laws. Lippis Enterprises retains all ownership and other rights in test data, the final test report, Lippis Report audio and video podcasts and any and all Lippis logos and/or trademarks used in connection with this test series.

Except as expressly provided for in this agreement, Lippis Enterprises makes no other warranties, express or implied, or arising by custom or usage of trade for any materials developed, delivered or provided hereunder, and specifically disclaims any implied warranties of merchantability or fitness for a particular purpose. Neither party hereto will be liable for lost profits, lost opportunities, or indirect, incidental, consequential, special, punitive or

exemplary damages, even if such party has been advised of the possibility of such damages. In no event will Lippis Enterprises' liability under this agreement for any form of action exceed the fees paid to Lippis Enterprises under this agreement.

With respect to claims or actions against one or both parties by third parties insofar as such claim, demand or action is attributable to sponsor's advertisement, the acts or omissions of sponsor, or a breach by sponsor of a representation and/or warranty made in this Agreement, sponsor shall (i) indemnify Lippis Enterprises against any liability, cost, loss, or expense of any kind; and (ii) hold harmless Lippis Enterprises and save it from any liability, cost, loss, or expense of any kind. Lippis Enterprises shall have the right to select and control legal counsel for the defense of any such claim, demand or action and for any negotiations relating to any such claim, demand or action; however, sponsor must approve any settlement of any such claim, demand or action to the extent that such settlement imposes any restrictions on or requires sponsor to contribute financially to such settlement.

Each party is acting as an independent contractor and not as an agent, partner, employee, or joint venture with the other party for any purpose. Neither party will have the right, power, or authority to act or to create any obligation, express or implied, on behalf of the other.

Our letter shall constitute the agreement between us, and any change must be confirmed in writing. This agreement will be interpreted according to the laws of the Commonwealth of Massachusetts.